

Semiconductor Switch

Solid State Relay LSE 01 Solid State Relay SSR 75 A

The PSG Solid State Relay is an extremely compact one phase SSR with or without heat sink that is fully pluggable to make installation and service easy. This zero cross switching relay can be used for resistive loads.

The standard control input terminal is equipped with screw terminals.



LSE 01



SSR 75 A

Description

- Zero cross Solid State Relay specially designed for resistive load
- Ready to use with heat sink
- 22.5 mm in space saving design
- Control range 3.5 to 32 VDC with input current limiter
- Output range 24 to 600 VAC 35 A
- „High efficiency back to back thyristor“ on output with TMS² technology for a long life expectancy
- Yellow input LED / input overvoltage protection
- IP 20 protection with flaps

Ordering designations

	Order number
LSE 01 / 30 A (with heat sink)	RRZ 2500/480VAC/35A/Kühlkörper
SSR 75 A (without heat sink)	RRZ 2500/480VAC/30A

Technical Data

Control characteristics (at 25°C)	
Control voltage	3.5-32 VDC
Control current (@ U _c)	< 14 mA
Release voltage	Min. 2 V
Input LED	Yellow
Reverse voltage	32 V
Input immunity EN61000-4-4	2 kV
Input immunity EN61000-4-5	2 kV
Output characteristics (at 25°C)	
Operating voltage range	24-600 VAC
Peak voltage	Min. 1200 V
Zero cross level	Max. 20 V
Latching voltage	Max. 10 V
Nominal current (AC-51)	(See curve page 4)
Non repetitive overload current	1200 A
On state voltage drop	Max. 0.9 V
On state dynamic resistance	Max. 4.5 mΩ
Output power dissipation (max. value)	$0.9 \times 0.9 \times I_e + 0.0045 \times I_e^2 W$
Thermal resistance between junction to case	0.4 K/W
Off state leakage current	Max. 1 mA
Minimum load current	Min. 5 mA
Turn on time	Max. 10 ms
Turn off time	Max. 10 ms
Operating frequency range	50-60 Hz
Off state du/dt	Min. 500 V/μs
Maximum di/dt non repetitive	Max. 50 A/μs
I ² t (<10 ms)	7200 As
Conducted immunity level according to IEC/EN61000-4-4 (bursts)	2 kV criterion B
Conducted immunity level according to IEC/EN61000-4-5 (surge)	2 kV criterion A with external VDR
Conducted and emitted interference according to IEC60947-4-3	Class A for Industrial applications
Fuse protection	Example: circuit breaker
General characteristics	
Input to output insulation	4000 Vrms
Output to case insulation	4000 Vrms
Insulation resistance	1000 (@ 500 VDC) MΩ
Rated impulse voltage	4000 V
Protection level	IP20 (with cover or flaps)
Vibration withstand 10/55 Hz according to IEC 600068-2-6	1.5 mm
Shock withstand according to IEC 600068-2-27	30 g _n
Ambient temperature (no icing, no condensation)	-40/+80 °C
Storage temperature (no icing, no condensation)	-40/+125 °C
Ambient humidity	40 to 85 %
Weight	230 g
Conformity	EN60947-4-3 (IEC947-4-3)
Conformity	EN60950 / UL / cUL
Housing material	PA 6 UL94V0
Base plate	Aluminum

Dimensions

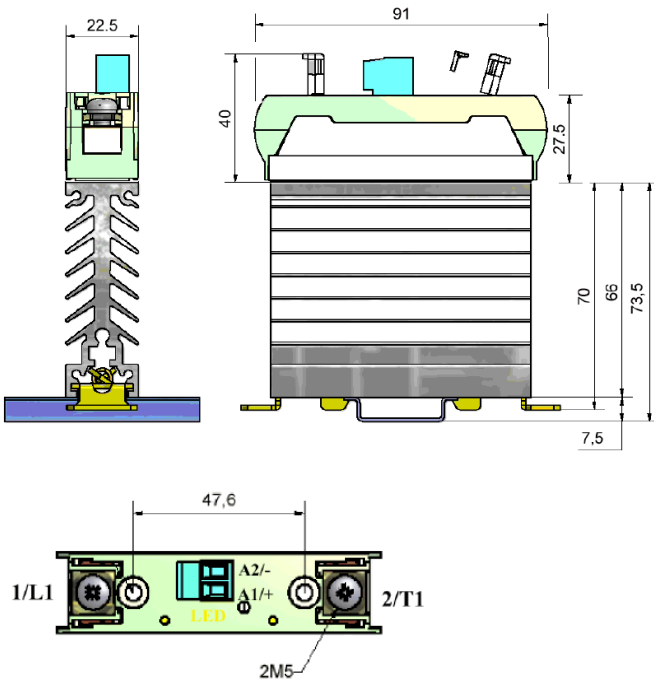



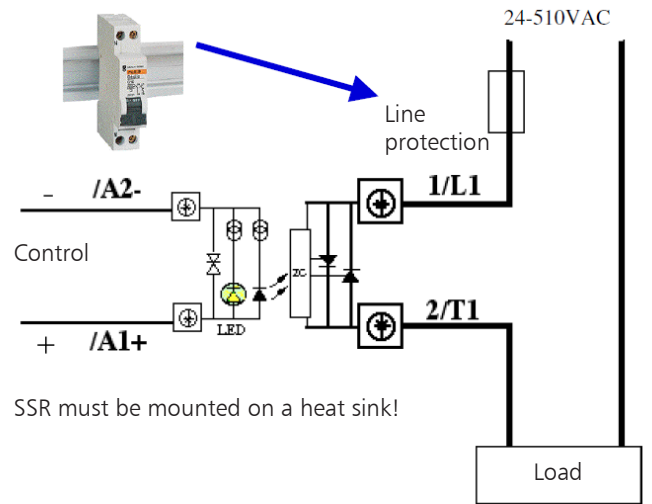

Functional diagram

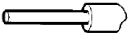

Typical application
10kW resistor
(AC-51 load)
on 400 VAC

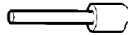
Load wiring

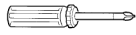
Number of wires				Screw driver type	Recommended torque
1		2			
Solid (no ferrule)	Fine Stranded (with ferrule)	Solid (no ferrule)	Fine Stranded (with ferrule)		
					M5 Nm
1.5 ... 10 mm ² AWG16 ... AWG8	1.5 ... 6 mm ² AWG16 ... AWG10	1.5 ... 10 mm ² AWG16 ... AWG8	1.5 ... 6 mm ² AWG16 ... AWG10	POZIDRIV 2	2

Direct connection with wires with or without ferrules



Washer for vibrations

With ring terminals

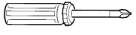

Control wiring

With 2 Points plug-gable connector	
0.13 to 3.3 mm	EN60999 a x b; d
AWG26 ... AWG12	2.8 mm x 2 mm ; 2.4 mm

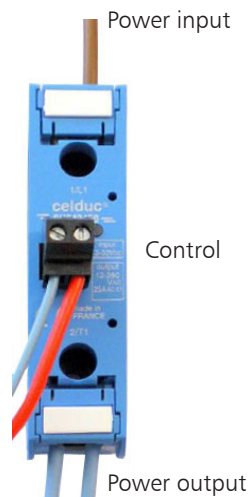

Mounting and dismounting on DIN rail

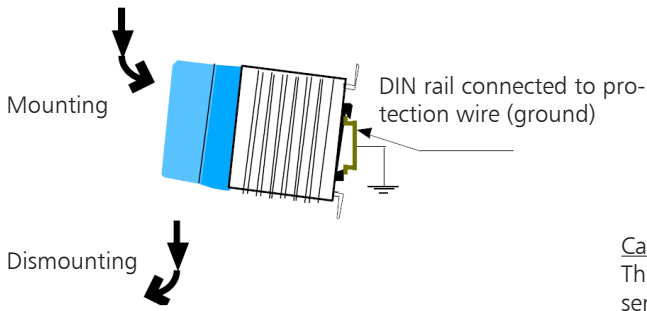

Panel mounting

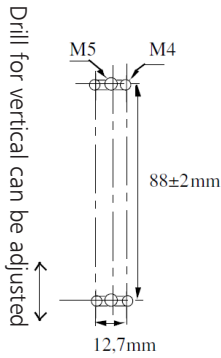

Caution:

The user should protect heat sensitive materials as well as persons against any contacts with the heat sink.

In case of no space between two SSR (zero space between two SSRs), please reduce the load current.

For a good cooling, the SSR needs an air convection.

A forced cooling (fan inside the cabinet) improves significantly the thermal performances.

In all cases please check the heat sink temperature never exceeds 90°C.

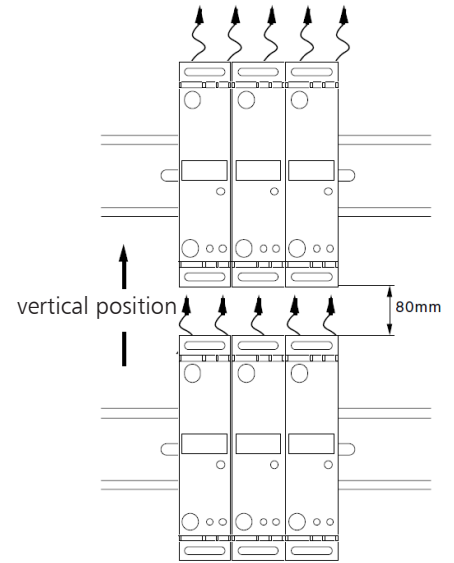

Thermal specification: Current according ambient temperature LSE 01 with heat sink

$$I_{\max} = f(T_{\text{ambient}})$$

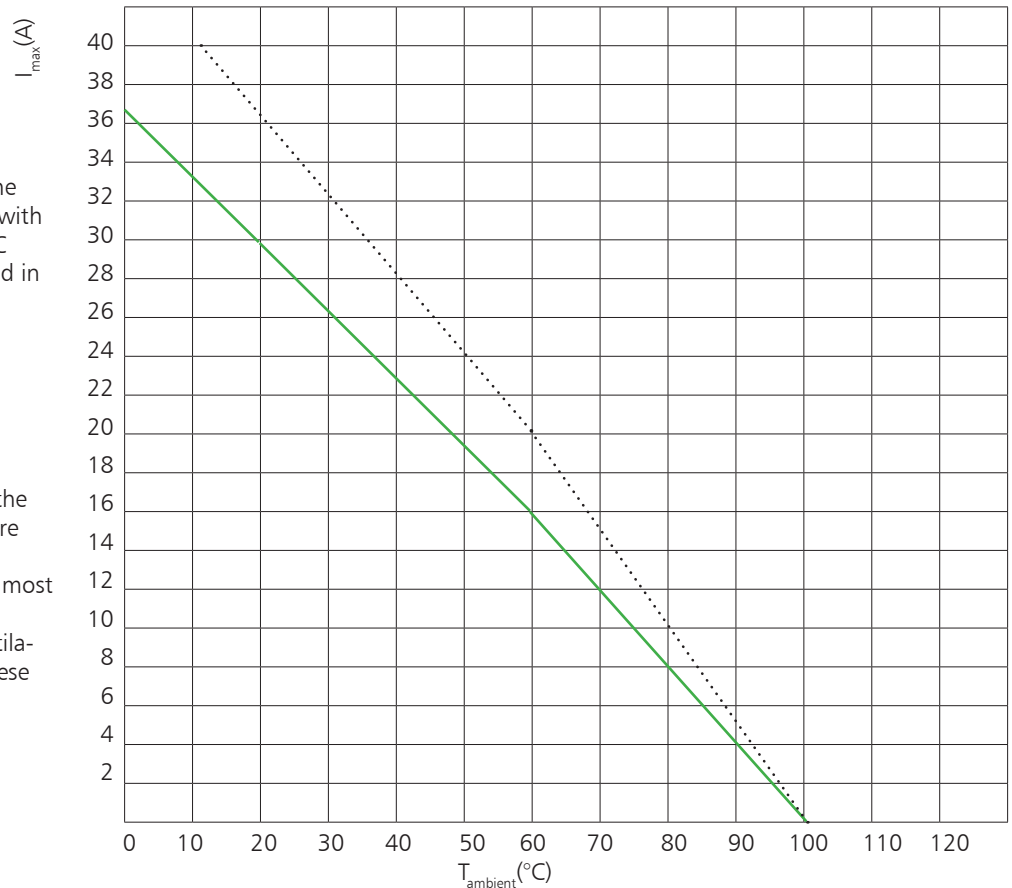

The green curve gives the limits of the product according to EN60947-4-3 with a maximum rise temperature of 50°C (@40°C) for a permanent current and in air calm (test during 8 hours).

The dotted curve gives the limits of the product. The temperature reached are acceptable for the components. These values are in compliance with most of SSRs manufacturers. In a cabinet with a minimum of ventilation or a non permanent current, these values are acceptable.